

EE434

ASIC and Digital Systems

Midterm Exam 2

Apr. 7, 2021. (2:10pm – 3pm)

Instructor: Dae Hyun Kim (daehyun@eecs.wsu.edu)

Name:

WSU ID:

Problem	Points	
1	10	
2	10	
3	15	
4	10	
5	10	
6	15	
Total	70	

Problem #1 (Static CMOS, 10 points)

Design the following function (draw a transistor-level schematic) using the static CMOS logic design methodology. Available input: A, B, C, D . # TRs should be less than or equal to 24.

$$Y = \overline{A \cdot \bar{B} + B \cdot \bar{C} + C \cdot \bar{D} + D \cdot \bar{A}}$$

Problem #2 (Transmission Gates, 10 points)

Design the following function (draw a transmission-gate-level schematic) using transmission gates only. Available input: $A, B, C, D, 0$ (GND), 1 (VDD).

$$Y = \overline{A \cdot \bar{B} + B \cdot \bar{C} + C \cdot \bar{D} + D \cdot \bar{A}}$$

You can use the following symbols for transmission gates.

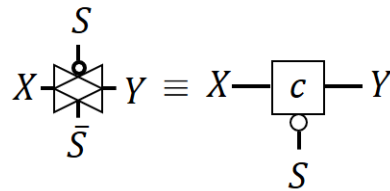
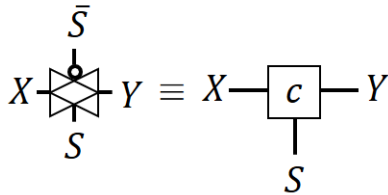

TGs ≤ 14 : 10 points, ≤ 16 : 7 points, ≤ 18 : 4 points

Problem #3 (TR Sizing, 15 points)

Size the transistors in the following schematic to satisfy the given timing constraint.

- R_n : The resistance of a 1X NFET.
- The delay should be $\leq R_n C_L$.
- Try to minimize the total transistor width.

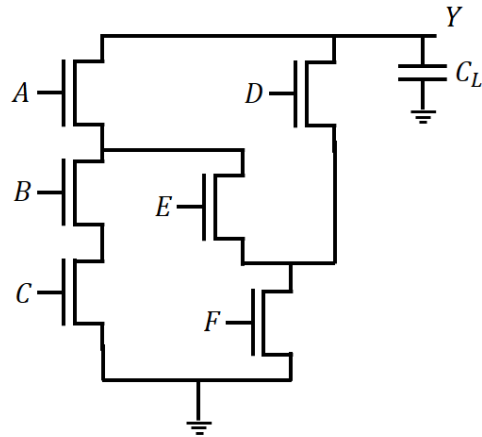

1) (10 points) Size the transistors. You will get 10 points if the total TR width is $\leq 22X$.

- A: X
- B: X
- C: X
- D: X
- E: X
- F: X

If the total TR width you obtained above is less than $22X$, you don't need to solve the second problem. You will get 15 points. If the width is greater than $22X$, you don't need to solve the second problem. You won't get the extra points. If the width is $22X$, solve the second problem.

2) (5 points) In your solution, you can upsize only one TR (and of course downsize all the other TRs as a result) to reduce the total TR width further. Which TR do you want to upsize?

Problem #5 (Logic Analysis, 10 points)

What does the following circuit do? Describe its functionality in as much detail as possible. (D: data input. CK: clock. Q: data output)

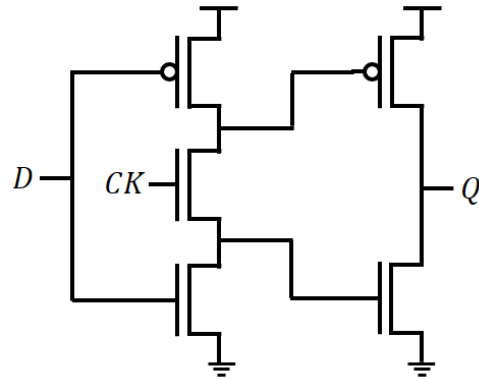

Problem #6 (Logic Design, 15 points)

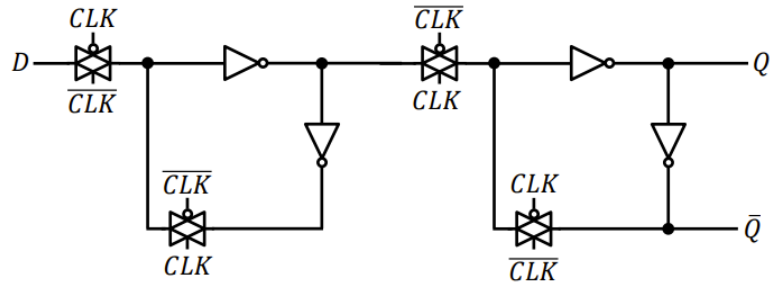

This is a positive-edge-triggered D flip-flop (FF). Can you modify the design (add some logic gates such as AND and OR to the design and/or remove some gates from the design, etc.) and add a control signal R to the design so that you can reset the D FF? Here is a more detailed description of the behavior of the logic.

- If $R = 1$, Q becomes 0 immediately regardless of D and CLK .
- If R switches from 1 to 0, Q should still be 0 until the next clock rising edge.